



CASTALY INDUSTRIES CORP.

637 VINELAND AVE. LA PUENTE, CA 91746

TEL: 626-968-6330 FAX: 626-968-6333

Mail: info@castalymachine.com Web Site www.lobomachine.com

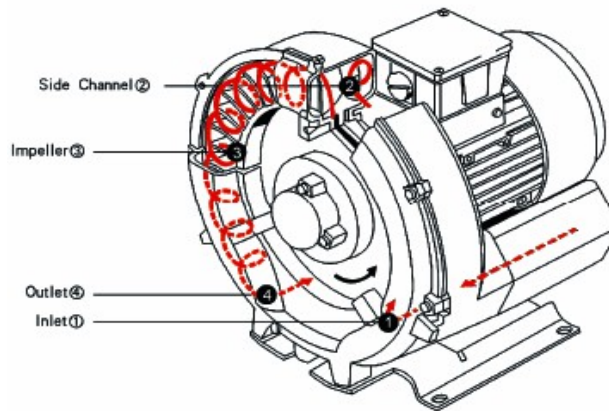
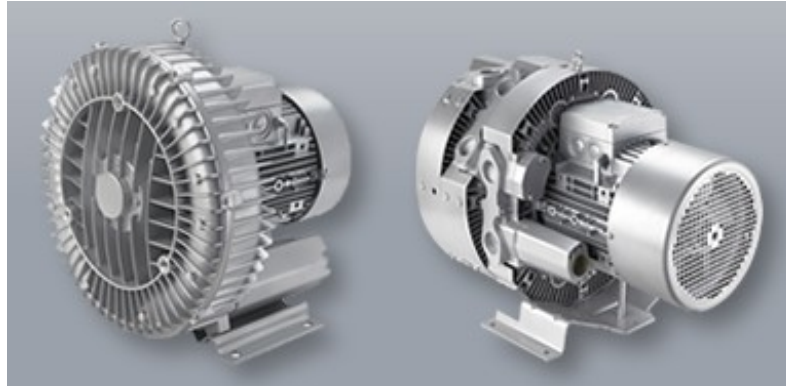

Side Channel Blower / Vacuum Pumps

Features:

- Centrifugal circulation, high pressure, large air volume. Air cushion, lower noise design. The aerodynamic torque is small, the working process are stable and reliable.
- Non oil circulation design, for clean environment processing
- Each type can be applied both as vacuum pump and compressor in continuous operation over the total stated performance curve range. The motors are available as standard for the input voltage range of 50 and 60 Hz and for protection category IP 55
- Relief-valve are available for limiting differential pressure.
- Measuring-surface sound-pressure level ACC to DIN EN 21680, measured at a distance of 1m.
- The pump is throttled to an average suction pressure, a hose is connected to the discharge side (compressor) / suction side (vacuum pump), but is not fitted with relief valves.
- The motors are designed according to the DIN EN 60 034 / DIN IEC 34-1 and temperature class F.
- For the three-phase machines the tolerances are +/- 10 % for fixed voltage and +/- 5 % for voltage range.
- The frequency tolerance is maximum +/- 2 %.
- The performance curves are based on air at a temperature of 15 °C and an atmospheric pressure of 1013 mbar with a tolerance of +/- 10 %. The total pressure differences are valid for suction and ambient temperatures up to 25 °C. For other conditions please confer with us.

Single Stage Side Channel Blower / Vacuum Pumps

Model	VC-SC055	VC-SC075	VC-SC110
Price	\$ 1,350.00	\$ 1,577.00	\$ 3,054.00
Power (KW)	6.3	8.6	12.6
Power (HP)	8.4	11.4	16.8
Max. Pressure (in. Hg)	14.1	16.5	21
Vacuum Capacity (in. Hg)	11.5	12	13.5
Air Flow (cfm)	319	336	644
Working Pressure (in. Hg)	10.2	12.3	13.9
Weight (LBS)	143	152	246
Machine Size (L x W x H)	19" x 17" x 18"	18" x 16" x 18"	26" x 22" x 23"

Price include Filter, Noise Reducer Pressure Relief Valve

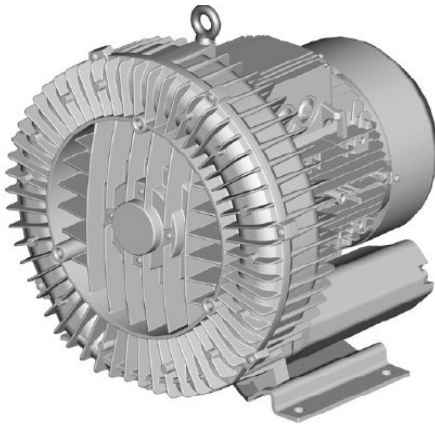

Input

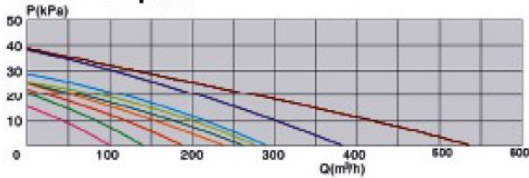

Output

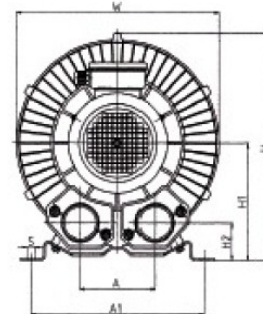
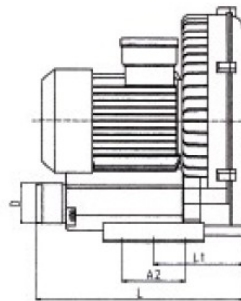
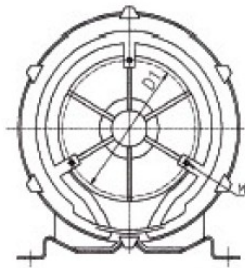
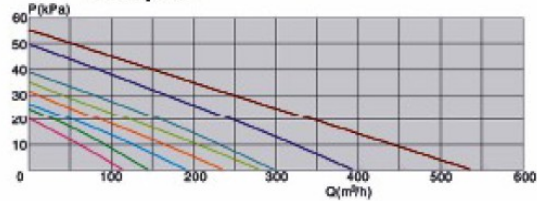

Dimensions	L	W	H	H1	H2	A	A1	A2	L1	D	D1	S	M
VC-SC055	486	418	453	236	73	135	320	200	138	φ76 (G2")	φ278	φ14	M8
VC-SC075	465	435	461	240	65	152	356	170	209	φ76 (G2")	φ290	φ14	M8
VC-SC110	648	551	571	301	93	207	360	520	260	φ113(G4")	φ491	φ16.5	M12

Double Stage Side Channel Blower / Vacuum Pumps

Model	VC-SC055-S	VC-SC075-S	VC-SC110-S
Price	\$ 1,579.00	\$ 1,806.00	\$ 3,283.00
Power (KW)	6.3	8.6	12.6
Power (HP)	8.4	11.4	16.8
Max. Pressure (in. Hg)	25.5	26.4	30.9
Vacuum Capacity (in. Hg)	15	15.6	16.8
Air Flow (cfm)	216	216	517
Working Pressure (in. Hg)	14.1	15.6	17.2
Weight (LBS)	152	162	252
Machine Size (L x W x H)	26" x 27" x 16"	27" x 27" x 16"	32" x 30" x 21"

Price include Filter, Noise Reducer Pressure Relief Valve

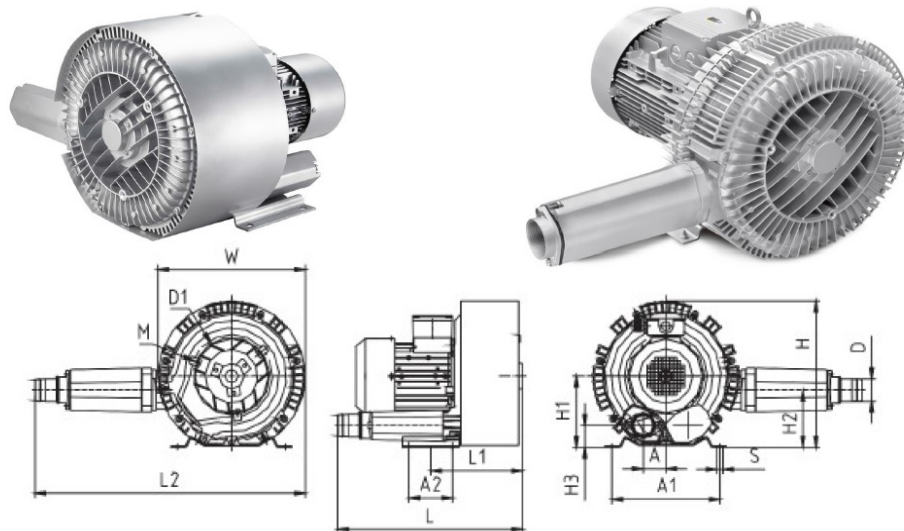

Dimensions	L	L2	W	H	H1	H2	H3	A	A1	A2	L1	D	D1	S	M
VC-SC055-S	652	702	426	408	195	157	89	150	290	140	277	ø60 (G2")	ø240	ø13	M8
VC-SC075-S	548	702	426	408	195	157	51	62	290	140	287	ø62 (G2")	ø240	ø14	M8

Standard Accessories



Air Filter

Pressure Relief Valve

Silencer

(Training and installation, tooling & rigging are optional.)

(Customer is responsible for local regulations and connecting utilities)

The price is F.O.B. Los Angeles Ca. USA. Tooling, rigging, freight & sales taxes are not included.

Full Payment with order or 50% deposit with confirm order, 50% before shipping.

If there are any questions please feel free to call us at 1-(626) 968-6330 or e-mail to us at info@castalymachine.com

(Price may vary, please check our website at www.cncroutergroup.com for the current price list)